

---

HP 423B  
HP 8470B  
Crystal Detectors

Operating and Service  
Manual

---

HP part number: 00423-90103  
Printed in USA  
April 1999

Revision 2.1

---

## Notice

The information contained in this document is subject to change without notice.

Hewlett-Packard makes no warranty of any kind with regard to this material, including, but not limited to, the implied warranties of merchantability and fitness for a particular purpose. Hewlett-Packard shall not be liable for errors contained herein or for incidental or consequential damages in connection with the furnishing, performance, or use of this material.

Hewlett-Packard assumes no responsibility for the use or reliability of its software on equipment that is not furnished by Hewlett-Packard.

This document contains proprietary information which is protected by copyright. All rights are reserved. No part of this document may be photocopied, reproduced, or translated to another language without prior written consent of Hewlett-Packard Company.

### **Restricted Rights Legend**

Use, duplication, or disclosure by the U.S. Government is subject to restrictions as set forth in subparagraph (c)(1)(ii) of the Rights in Technical Data and Computer Software clause at DFARS 252.227-7013 for DOD agencies, and subparagraphs (c)(1) and (c)(2) of the Commercial Computer Software Restricted Rights clause at FAR 52.227-19 for other agencies.

Hewlett-Packard Company  
Santa Rosa Systems Division  
1400 Fountaingrove Parkway  
Santa Rosa, CA 95403-1799, U.S.A.

© Copyright Hewlett-Packard Company 1975, 1977, 1979, 1998, 1999

---

## Warranty

### Certification

*Hewlett-Packard Company certifies that this product met its published specifications at the time of shipment from the factory. Hewlett-Packard further certifies that its calibration measurements are traceable to the United States National Institute of Standards and Technology (NIST, formerly NBS), to the extent allowed by the Institute's calibration facility, and to the calibration facilities of other International Standards Organization members.*

### Warranty

This Hewlett-Packard system product is warranted against defects in materials and workmanship for a period corresponding to the individual warranty periods of its component products. Instruments are warranted for a period of one year. During the warranty period, Hewlett-Packard Company will, at its option, either repair or replace products that prove to be defective.

Warranty service for products installed by HP and certain other products designated by HP will be performed at Buyer's facility at no charge within HP service travel areas. Outside HP service travel areas, warranty service will be performed at Buyer's facility only upon HP's prior agreement and Buyer shall pay HP's round trip travel expenses. In all other areas, products must be returned to a service facility designated by HP.

For products returned to HP for warranty service, Buyer shall prepay shipping charges to HP and HP shall pay shipping charges to return the product to Buyer. However, Buyer shall pay all shipping charges, duties, and taxes for products returned to HP from another country.

HP warrants that its software and firmware designated by HP for use with an instrument will execute its programming instructions when properly installed on that instrument. HP does not warrant that the operation of the instrument, or software, or firmware will be uninterrupted or error free.

**LIMITATION OF WARRANTY.** The foregoing warranty shall not apply to defects resulting from improper or inadequate maintenance by Buyer, Buyer-supplied software or interfacing, unauthorized modification or misuse, operation outside of the environmental specifications for the product, or improper site preparation or maintenance.

**NO OTHER WARRANTY IS EXPRESSED OR IMPLIED. HP SPECIFICALLY DISCLAIMS THE IMPLIED WARRANTIES OR MERCHANTABILITY AND FITNESS FOR A PARTICULAR PURPOSE.**

**EXCLUSIVE REMEDIES.** THE REMEDIES PROVIDED HEREIN ARE BUYER'S SOLE AND EXCLUSIVE REMEDIES. HP SHALL NOT BE LIABLE FOR ANY DIRECT, INDIRECT, SPECIAL, INCIDENTAL, OR

CONSEQUENTIAL DAMAGES, WHETHER BASED ON CONTRACT, TORT, OR ANY OTHER LEGAL THEORY.

## **Assistance**

Product maintenance agreements and other customer assistance agreements are available for Hewlett-Packard products.

For assistance, call your local Hewlett-Packard Sales and Service Office (refer to “Service and Support” on page v).

---

## Service and Support

Any adjustment, maintenance, or repair of this product must be performed by qualified personnel. Contact your customer engineer through your local HP Service Center. You can find a list of HP Service Centers on the web at <http://www.hp.com/go/tmdir>.

If you do not have access to the Internet, one of these HP centers can direct you to your nearest HP representative:

---

<b>United States:</b>	Hewlett-Packard Company Test and Measurement Call Center PO Box 4026 Englewood, CO 80155-4026 (800) 452 4844 (toll-free in US)
<b>Canada:</b>	Hewlett-Packard Canada Ltd. 5150 Spectrum Way Mississauga, Ontario L4W 5G1 (905) 206 4725
<b>Europe:</b>	Hewlett-Packard European Marketing Centre Postbox 999 1180 AZ Amstelveen The Netherlands (31 20) 547 9900
<b>Japan:</b>	Hewlett-Packard Ltd. Measurement Assistance Center 9-1, Takakura-Cho, Hachioji-Shi Tokyo 192, Japan (81) 426 56 7832 (81) 426 56 7840 (FAX)
<b>Latin America:</b>	Hewlett-Packard Latin American Region Headquarters 5200 Blue Lagoon Drive, 9th Floor Miami, Florida 33126, U.S.A. (305) 267 4245, (305) 267-4220 (305) 267 4288 (FAX)
<b>Australia/New Zealand:</b>	Hewlett-Packard Australia Ltd. 31-41 Joseph Street Blackburn, Victoria 3130 Australia 1 800 629 485 (Australia) 0800 738 378 (New Zealand) (61 3) 9210 5489 (FAX)
<b>Asia-Pacific:</b>	Hewlett-Packard Asia Pacific Ltd. 17-21/F Shell Tower, Times Square 1 Matheson Street, Causeway Bay Hong Kong (852) 2599 7777 (852) 2506 9285 (FAX)

---

---

## Safety and Regulatory Information

Review this product and related documentation to familiarize yourself with safety markings and instructions before you operate the instrument. This product has been designed and tested in accordance with international standards.

---

### WARNING

---

The **WARNING** notice denotes a hazard. It calls attention to a procedure, practice, or the like, that, if not correctly performed or adhered to, could result in personal injury. Do not proceed beyond a **WARNING** notice until the indicated conditions are fully understood and met.

---









### CAUTION

---

The **CAUTION** notice denotes a hazard. It calls attention to an operating procedure, practice, or the like, which, if not correctly performed or adhered to, could result in damage to the product or loss of important data. Do not proceed beyond a **CAUTION** notice until the indicated conditions are fully understood and met.

## Instrument Markings

---

	When you see this symbol on your instrument, you should refer to the instrument's instruction manual for important information.
	This symbol indicates hazardous voltages.
	The laser radiation symbol is marked on products that have a laser output.
	This symbol indicates that the instrument requires alternating current (ac) input.
	The CE mark is a registered trademark of the European Community. If it is accompanied by a year, it indicates the year the design was proven.
	The CSA mark is a registered trademark of the Canadian Standards Association.
1SM1-A	This text indicates that the instrument is an Industrial Scientific and Medical Group 1 Class A product (CISPER 11, Clause 4).
	This symbol indicates that the power line switch is ON.
	This symbol indicates that the power line switch is OFF or in STANDBY position.

---

---

# Contents

Description .....	3
Installation .....	4
Initial Inspection .....	4
Storage and Shipment .....	4
<i>Table 1. Specifications</i> .....	5
Operating Information .....	6
Operator Checks .....	7
<i>Figure 1. Peak Power Measurement</i> .....	7
Performance Tests .....	8
Frequency Response Test .....	8
High Level Sensitivity Test .....	8
Low Sensitivity Test .....	8
Match Test (SWR) .....	8
Service Instructions .....	9
Replaceable Parts .....	9
Detector Element Replacement .....	9
Load Resistor Parts Replacement .....	10
<i>Figure 2. Cutting Center Conductor Lead to Accommodate</i> Contact Spring .....	11
<i>Figure 3. Load Resistor, Cutaway View</i> .....	11
<i>Figure 4. HP 423B Crystal Detector</i> .....	12
<i>Figure 5. HP 8470B and HP 8470B Option 012 Crystal</i> Detector Assemblies .....	12
APC-7 Connectors .....	14
<i>Figure 6. Use and Care of APC-7 Connectors</i> .....	14





---

## Description

The HP 423B and HP 8470B crystal detectors are 50  $\Omega$  (nominal) Schottky diode devices designed for measurement use in coaxial systems.

- Features**
- The instruments convert the RF power levels applied to the 50  $\Omega$  input connector into proportional values of dc voltage.
  - The instruments measure relative power up to 200 mW and have a BNC female connector for the output jack which allows the detected output to be connected to a SWR meter.
  - The output voltage polarity is negative, unless Option 003 is selected.
  - The frequency range of the HP 423B is 10 MHz to 12.4 GHz.
  - The frequency range of the HP 8470B is 10 MHz to 18 GHz.
  - AM modulation can be detected up to about 1 MHz.

**Options** The HP 423B and HP 8470B crystal detectors are available with the following non-exclusive options. (Refer to Table 1 for further descriptions.)

- |             |   |
|-------------|---|
| Option 001: | Matched pair of detectors   |
| Option 002: | Furnished with matched load resistor for optimum square law characteristics |
| Option 003: | Positive polarity output  |
| Option 012: | Furnished with stainless steel type N male connectors (HP 8470B only)       |

- Connectors**
- The mating RF input connectors used with the HP 423B and HP 8470B Option 012 must be type N female connectors which comply with U.S. military standard MIL-C-39012.
  - The HP 8470B (standard) RF input connector must be an 7-mm connector.
  - The mating output connector for the HP 423B and HP 8470B must be a BNC male.

---

## Installation

### Initial Inspection

1. Inspect the shipping container for damage. If the shipping container or cushioning material is damaged, it should be kept until the contents of the shipment have been checked for completeness and the instrument has been checked mechanically and electrically. Procedures for checking electrical performance are given under Performance Tests.
2. If the contents are incomplete, if there is mechanical damage or defect, or if the instrument does not pass the electrical performance test, contact the nearest Hewlett-Packard office. Refer to “Service and Support” on page v. Hewlett-Packard will arrange for repair or replacement of the damaged or defective equipment. Keep the shipping materials for the carrier’s inspection.
3. If you are returning the instrument for service, repackaging the instrument requires original shipping containers and materials or their equivalents. Hewlett-Packard can provide packaging materials identical to the original materials. Refer to “Service and Support” on page v. Attach a tag indicating the type of service required, return address, model number and serial number. Mark the container **FRAGILE** to insure careful handling. In any correspondence, refer to the instrument by model number and serial number.

### Storage and Shipment

The instrument should be stored in a clean, dry environment. The following environmental limitations apply to both storage and shipment:

- a. Temperature: -54 to +85 °C
- b. Altitude < 7620 meters (25,000 feet)
- c. Humidity < 95% relative
- d. Shock 100 G for 11 ms
- e. Vibration 20 G from 80 to 2000 Hz

Table 1 Specifications

<p><b>Frequency Range:</b></p> <p><b>HP 423B:</b> 10 MHz to 12.4 GHz  <b>HP 8470B:</b> 10 MHz to 18 GHz</p> <p><b>Note:</b> RF may leak through the output connector below 1 GHz. It can be reduced, if objectionable, with a suitable low pass filter.</p> <p><b>Frequency Response:</b><sup>4, 5</sup></p> <p><b>HP 423B and HP 8470B:</b>  Octave flatness:  <math>\pm 0.2</math> dB over any octave 10 MHz to 8 GHz  Broadband flatness:  <math>\pm 0.3</math> dB 10 MHz to 12.4 GHz</p> <p><b>HP 8470B only:</b>  Broadband flatness:  <math>\pm 0.5</math> dB 10 MHz to 15 GHz  <math>\pm 0.6</math> dB 10 MHz to 18 GHz</p> <p><b>SWR</b><sup>1,2</sup> (Max):  <b>HP 423B and HP 8470B:</b>  10 MHz to 4 GHz, 1.15  4 GHz to 12.4 GHz, 1.3</p> <p><b>Maximum Operating Input Power:</b>  200 mW, peak or average</p> <p><b>Maximum Short Term Input Power:</b>  1 watt (typical) peak or average for &lt; 1 minute</p> <p><b>Sensitivity:</b><sup>1, 3, 5</sup></p> <p>High level: &lt; 0.35 mW produces 100 mV output  Low level: &gt; 0.5 mVdc/<math>\mu</math>W CW</p> <p><b>Input Impedance:</b> 50 <math>\Omega</math> (nominal)</p> <p><b>Output Impedance:</b><sup>2</sup> 1 to 2 k <math>\Omega</math> (typically 1.3 k <math>\Omega</math>) shunted by 35 to 65 pF (typically 50 pF).</p> <p><b>Output Polarity:</b> Negative (refer to options for positive polarity units).</p> <p><b>Detector Element:</b> Supplied (refer to Table 2 for replacement elements)</p> <p><b>Bias:</b> Not required</p> <p><b>Noise:</b> &lt; 50 <math>\mu</math>Vpp with CW applied to produce 100 mV output.</p>	<p><b>Options:</b></p> <p><b>HP 423B and HP 8760B:</b></p> <p><b>Option 002:</b> Furnished with matched load resistor for optimum square law characteristics of 25 ° C, within <math>\pm 0.5</math> dB from square law over a range of at least 30 dB up to 10 mV peak output, working into an external load &gt; 8 k <math>\Omega</math>. Sensitivity typically is greater than 0.1 mV/<math>\mu</math>W when load resistor is used.</p> <p><b>Option 003:</b> Positive polarity output</p> <p><b>HP 423B:</b></p> <p><b>Option 001:</b> Matched detector pair. Frequency response characteristics (exclusive of basic sensitivity) track within <math>\pm 0.2</math> dB from 10 MHz to 12.4 GHz at -30 dBm.</p> <p><b>HP 8760B:</b></p> <p><b>Option 001:</b> Matched detector pair. Frequency response characteristics (exclusive of basic sensitivity) track within <math>\pm 0.2</math> dB from 10 MHz to 12.5 GHz; <math>\pm 0.3</math> dB from 12.4 GHz to 18 GHz at -30 dBm.</p> <p><b>Option 012:</b> Furnished with stainless steel type N male connector.</p> <p><b>Environmental:</b></p> <p><b>HP 432B:</b>  Operating temperature: 0 ° C to +55 ° C  Humidity: &lt; 95% relative  Vibration: 20 G from 80 to 2000 Hz  Shock: 100 G for 11 ms  Altitude: &lt; 4570 meters (15,000 feet)</p> <p><b>HP 8760B:</b>  Operating temperature: -20 to +85 ° C  Humidity: &lt; 95% relative  Vibration: 20 G from 80 to 2000 Hz  Shock: 100 G for 11 ms  Altitude: &lt; 4570 meters (15,000 feet)</p> <p><b>General:</b>  Weight:  <b>HP 423B and HP 8760B:</b> Net 114 g (4 oz.)  Dimensions:  <b>HP 423B:</b> 63 mm long, 20 mm diameter (2.47 in. long, 0.78 in. diameter)  <b>HP 8760B:</b> 64 mm long, 19mm diameter (2.50 in. long, 0.75 in. diameter)</p>
<p>1 Specifications given for +25 ° C unless otherwise noted.  2 Measurement made at -20 dBm.  3 Sensitivity decreases with increasing temperature, typically:  0.5 dB from -20 to +25 ° C; 0.5 dB from +25 to +40° C;  1 dB from +40 to +55 ° C; 1.25 dB from +55 to +75 ° C; 1 dB from +75 to +85 ° C;  4 Measured at -30 dBm. Flatness is the peak-to-valley range of the response.  5 External load resistance &gt; 50 k <math>\Omega</math></p>	

## Operating Information

The crystal detector can be used as a demodulator to obtain a pulse envelope which can then be observed on an oscilloscope. It can also be used as a general purpose detector.

---

### CAUTION

Static discharge can damage the detector element. A 100 pF capacitor (1.2 m [4 ft] of coax cable) charged to 14 volts stores .1 erg, the maximum pulse rating of the detector element.

- Connect cables to test equipment and discharge the center conductor before connecting to the detector.
- **DO NOT NEEDLESSLY HANDLE THE DETECTOR ELEMENT USED IN CRYSTAL DETECTOR.** Static electricity which builds up on a person, especially on a cold dry day, must never be allowed to discharge through the crystal detector.
- Avoid exposed leads to or from the crystal detector, since these are often touched accidentally.

---

The power applied to the detector can be either modulated or continuous wave (CW). If modulated at a 1000 Hz rate, an SWR meter can be used as an indicator. For CW detection, a dc milliammeter or millivoltmeter can be used as the indicator.

---

### NOTE

When using the crystal detector with an oscilloscope, and the waveshapes to be observed have rise times of less than 5 $\mu$ s, the coaxial cable connecting oscilloscope and detector should be as short as possible and shunted with a resistor.

Ideally, this resistor should be 50  $\Omega$  to terminate the coaxial cable properly. However, with 50  $\Omega$  resistance, the output video pulse may be too small to drive some oscilloscopes. Therefore, the cable should be shunted with the smallest value of resistance that will obtain suitable deflection on the oscilloscope; typically the value will lie between 50 $\Omega$  and 2k $\Omega$ . The larger the resistance the more degradation of rise time.

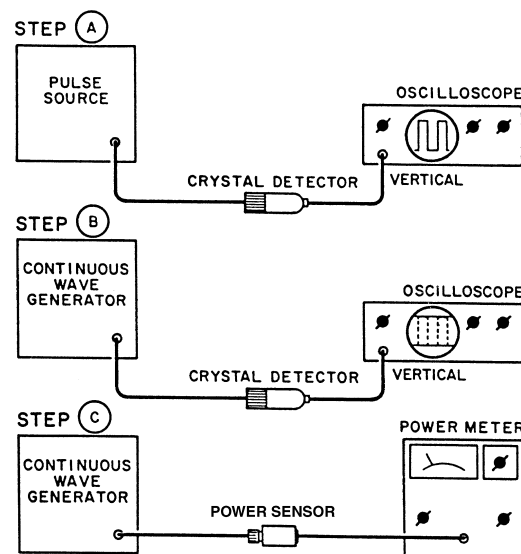
---

## Operator's Check

### Peak Power Measurement

The procedure for peak power measurement involves calibration of an oscilloscope which, in turn, is used to calibrate a CW generator. The output of the calibrated CW generator is measured with a power meter; the peak power of a pulse is thereby measured. The procedure is as follows:

1. Connect equipment as shown in Figure 1, step A. Observe the pulse on a de-coupled oscilloscope. Using a marking pencil, mark on the graticule the base-to-peak amplitude of the pulse envelope.
2. Replace the pulse source with a CW generator. While observing the oscilloscope trace, adjust the amplitude of CW generator output to make detector's output equal to that of pulse generator, as indicated by markings on the graticule (step A).
3. Leave the CW generator at setting obtained in step B. Disconnect the detector from CW generator.
4. Connect the output of CW generator to the power meter (step C). Measure the adjusted levels (set in step B) of the CW generator output. The peak power of the pulse envelope observed in step A is equal to the output power of the CW generator.



**Figure 1** Peak Power Measurement

### Reflectometer Application

For information about reflectometer systems and measurements refer to Hewlett-Packard Application Note Index. Copies are available upon request.

### Harmony Frequency Comparison Measurement Application

The detector can be used as a mixer in harmonic-frequency comparison measurements. Refer to Hewlett-Packard Application Note Index for further information.

---

## Performance Tests

Methods for testing detector specifications are given below. Refer to the manuals of the equipment involved for operating instructions.

---

### NOTE

---

Multiple mismatch errors caused by attenuator SWR, power meter SWR, and detector SWR should be taken into account, as well as the accuracy of the indicator used to measure the detector's output.

### Frequency Response Test

1. Using signal sources covering 10 MHz to 18 GHz with a 10 dB isolating attenuator and a power meter, connect the power sensor to the attenuator. Adjust the RF power level to -20 dBm input to the power sensor.
2. Without changing the RF power level of signal source, disconnect the power sensor.
3. Connect the detector to the attenuator. Measure the dc voltage output and record the measurement.
4. Change the frequency of the signal source and repeat steps 1 through 3.
5. Since the detector follows a square-law response at this power level, its output is proportional to power ( $P_{dB} = 10 \log V_o$ ). Total variation of detector readings should meet specifications (refer to Table 1) for all frequencies of interest across the band.

### Higher Level Sensitivity Test

1. Using signal sources covering 10 MHz to 18 GHz and a dc voltmeter or oscilloscope as the indicator, connect the detector to the signal source. Adjust the RF power level for a 100 mV detected output from the detector, using a CW signal.
2. Disconnect the detector from the signal source and measure the RF output level. The RF output level should be  $\leq 0.35$  mW.
3. Repeat steps 1 and 2 for all frequencies of interest across the band.

### Low Level Sensitivity Test

1. Using a signal source (covering 10 MHz to 18 GHz), a 10 dB attenuator, and a power meter, connect the attenuator to the signal source and power sensor to the attenuator. Adjust the RF power level for -20 dBm output from the attenuator. Verify the ambient temperature.
2. Disconnect the power sensor from the attenuator and connect the detector. Measure the dc voltage output from the detector. The output should be  $> 5.0$  mV at  $25^\circ\text{C}$ . Between  $20^\circ\text{C}$  and  $30^\circ\text{C}$  the sensitivity slope is typically  $-0.04$  dB/ $^\circ\text{C}$ .

### Match Test (SWR)

1. To verify the detector's SWR specifications, use any system whose measurement accuracies for SWR (residual SWR) are known.

---

## Service Instructions

Repair and replacement information for the HP 432B and HP 8470B crystal detectors and Option 002 load resistor are given below. For additional maintenance information refer to “Service and Support” on page v for the nearest Hewlett-Packard Sales and Service office. The detectors have no internal adjustments.

### Replaceable Parts

Part numbers for replaceable parts are given in Table 2. To order a replacement part, address your order or inquiry to the nearest Hewlett-Packard office. Refer to “Service and Support” on page v. Include the model number, Hewlett-Packard part number, and a description.

### Detector Element Replacement

The detector element assembly includes only a detector element. However, Option 002 does include a resistor for the load resistor which is used to load the diode for square-law operation.

---

#### CAUTION

Read the following precautions carefully before performance of any operation with the detector element when it is out of either the housing or the detector element shipping container.

- Before installing the diode into the mount, touch the exposed metal on the mount with your hand to discharge static electricity.
- When handing the diode to another person, first touch hands to ensure that there is no difference in static electricity potential between you.
- Ohmmeters should not be used to measure forward- and back-resistance since it is easy to damage these diodes. The ohmmeter’s open-circuit voltages and short-circuit currents may cause problems.

1. Remove the female BNC connector and compression spring from inside of the connector cap.
2. Remove the connector cap from the body. Use a pair of pliers with plastic jaws or protect the body with heavy paper or tape.

---

#### CAUTION

- Do not rotate the detector element while inserting or removing as damage may result.
- When inserting the detector element, do not force the large pin end into the center conductor.
- The detector element might be damaged if the detector element is not centered.

## Service Instructions

3. Remove the old detector element, axial spacer, and RF washer and discard the detector element.
4. Install the RF washer, axial spacer, and new detector element. Refer to Figures 4 and 5 for proper orientation for the internal components.
  - a. Insert the RF washer first.
  - b. Then carefully insert the large pin end of the detector element into the center contact inside the detector body.
  - c. Place the axial spacer over the small pin end of the detector element.
5. Carefully place the connector cap over the body and assembled components and tighten firmly in place.
6. Place the compression spring into the center conductor of the female BNC connector. Carefully start the spring over the small pin of the detector element through the hole in the connector cap. Keep the spring in the BNC connector and screw the female BNC connector firmly into place.

## Load Resistor Parts Replacement

### To replace the male BNC connector

Parts referred to in the following procedures are identified in Figure 2 and Figure 3.

1. Remove the male BNC connector and lock washer from the housing.

Use a 3/8-inch open-end wrench and hold the housing either in a vise or with pliers. Be sure to protect the housing of the load resistor with material such as heavy paper or tape or use plastic jaws on the vise or pliers.
2. Unsolder the resistor.
3. Solder the resistor to the new BNC connector.
4. Let the resistor cool and then check the resistance from male BNC pin through the resistor. The resistance measurement should be  $\pm 10\%$  than indicated by the color coding.
5. Replace the lockwasher and male BNC connector.

### To replace the female BNC connector

1. Remove the female BNC connector. Refer to Figure 3 for parts identification.

To remove or install the BNC connector, use a BNC wrench or use a male BNC connector as a wrench to prevent damage to the connector.

2. Unsolder the contact spring.



3. Prepare the replacement female BNC connector:
  - a. Cut the center conductor lead to approximately 0.79 mm (1/32 in.)
  - b. With a flat file, smooth the end of the lead; remove burr with tweezers of similar metal instrument.
4. Slip the contact spring over the center conductor lead, and solder.

---

**CAUTION**

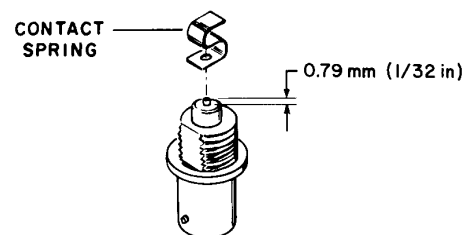

---

Use solder sparingly or it will creep back on the spring. Solder on the spring will destroy its usefulness and it is difficult to remove.

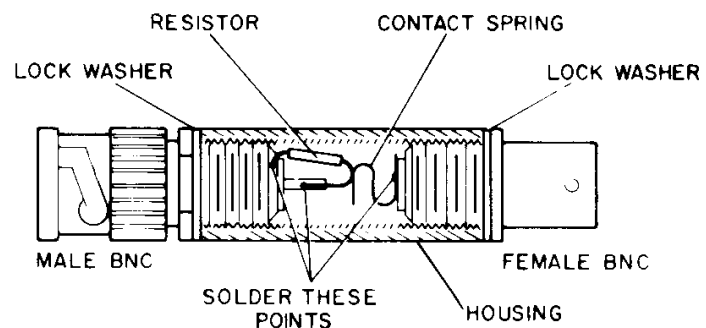
5. Let the contact spring cool and then screw the connector into the mount.

**To replace the 7-mm connector center contact**

1. Refer to “7-mm Connectors” on page 12 for assembly and disassembly instructions.
2. Refer to “Replacing the 7-mm Center Contact” on page 13 for the center contact replacement procedure.

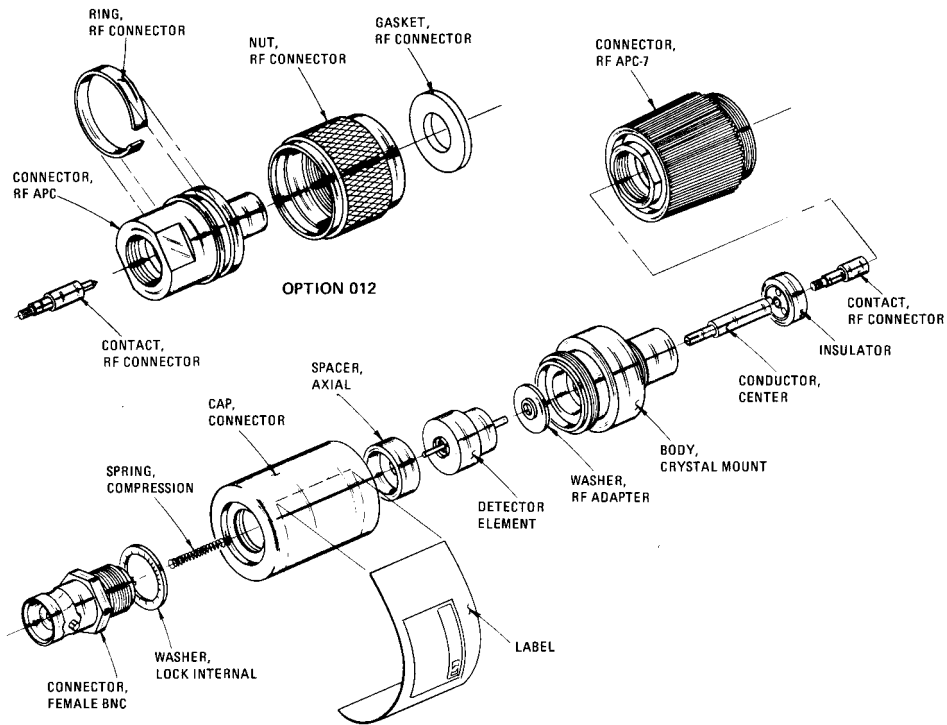


**Figure 2** Cutting Center Conductor Lead to Accommodate Contact Spring

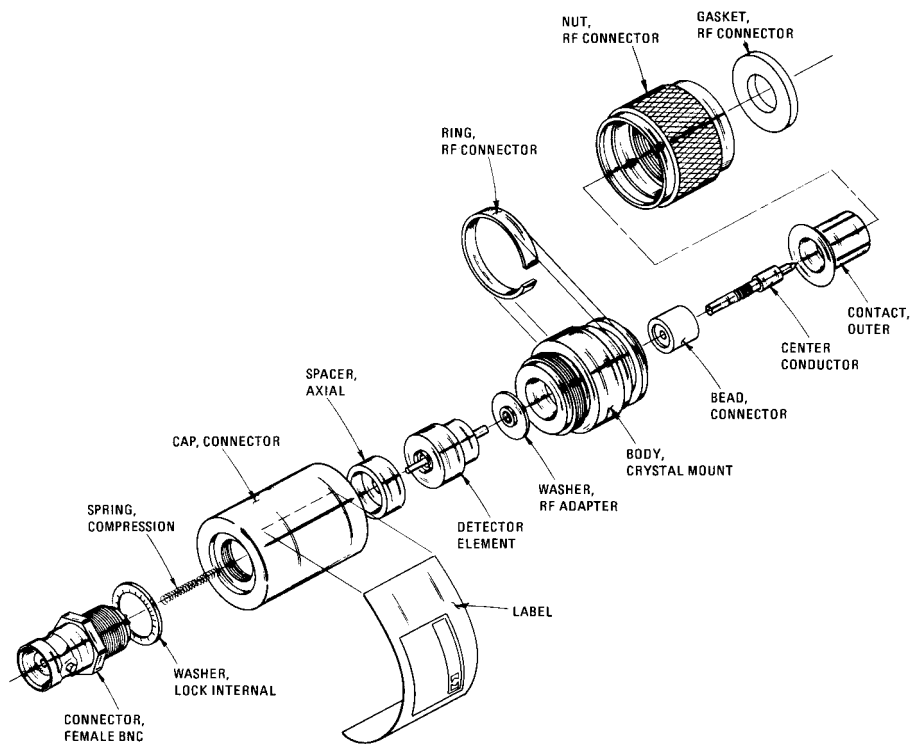


**Figure 3** Load Resistor, Cutaway View

## Service Instructions



**Figure 4** HP 423B Crystal Detector



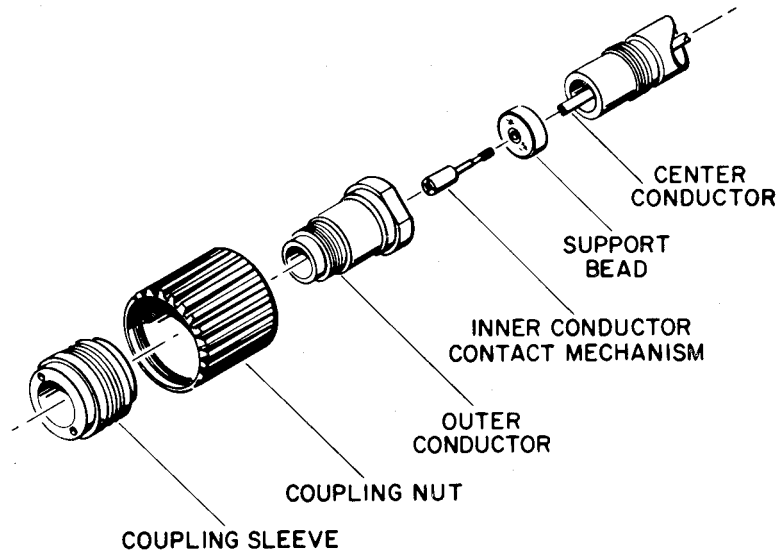
**Figure 5** HP 8470B and HP 8470B Option 012 Crystal Detector Assemblies

Description	Part Number	Description	Part Number
<b>HP 423B Assembly</b>		Connector, RF 7 mm	1250-0909
Contact, RF connector	1250-0014	Spring, compression	1460-0072
Gasket, RF connector	1250-0015	Washer, lock internal	2190-0016
Ring, RF connector	1250-0016	Cap, connector	5020-0210
Connector, female BNC	1250-0212	Washer, cap	5021-0127
Nut, RF connector	1250-0918	Insulator	5040-0306
Spring, compression	1460-0072	Conductor, center	08470-20002
Washer, lock internal	2190-0016	Ring, RF connector (Opt 012)	1250-0016
Bead, connector	5020-0207	Connector, RF APC (Opt 012)	1250-0916
Cap, connector	5020-0210	Contact, RF connector (Opt 012)	1250-0917
Washer, cap	5021-0127	Nut, RF connector (Opt 012)	1250-0918
Conductor, center	00423-201		
Body, crystal mount	00423-202	<b>Replacement Diode Assemblies<sup>1</sup></b>	
		Single diode negative polarity	08470-6001
		Single diode positive polarity (Opt 003)	08470-60013
		Single diode negative polarity with matching load resistor (Opt 002)	08470-60014
		Single diode positive polarity with matching load resistor (Opt 002)	08470-60015
		<b>HP 8470B 7-mm Connector Assembly</b>	
		Inner conductor contact mechanism (assembled contact and outer body)	1250-0816
		Coupling nut	1250-0918
		Coupling sleeve	1250-0820
		Inner conductor contact	1250-0907
		Support bead	5040-0306
		Tools <sup>2</sup>	
		7-mm contact extractor	5060-0370
		7-mm spanner wrench	5060-0237
		Open-end wrench	8710-0877
<b>Replacement Diode Assemblies<sup>1</sup></b>			
Single diode negative polarity	00423-60003		
Single diode positive polarity (Opt 003)	00423-60004		
Single diode negative polarity with matching load resistor (Opt 002)	00423-60005		
Matched pair diodes negative polarity (Opt 001)	00423-60007		
<b>Load Resistor Assembly<sup>2</sup></b>			
Connector, male BNC	1250-0045		
Connector, female BNC	1250-0251		
Spring, contact	5000-0234		
Housing	5020-3215		
<b>HP 8470B and HP 8470B-012 Assemblies<sup>1</sup></b>			
Connector, female BNC	1250-0212		
Contact, RF connector	1250-0816		

<sup>1</sup> Refer to Table 1 for description of options.

<sup>2</sup> Part of HP 11591A 7-mm Connector Tool Kit

## 7-mm Connectors



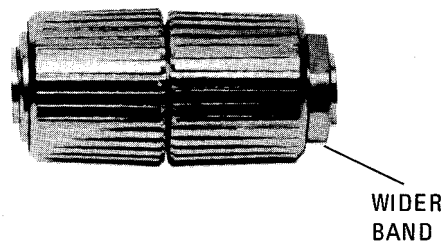
**Figure 6** *Use and Care of 7-mm Connectors*

### To Connect

1. On one connector, retract the coupling sleeve by turning the coupling nut counterclockwise until the sleeve and nut disengage.
2. On the other connector, fully extend the coupling sleeve by turning the coupling nut clockwise. To engage coupling sleeve and coupling nut when the sleeve is fully retracted, press back lightly on the nut while turning it clockwise.
3. Push the connectors firmly together, and thread the coupling nut of the connector with retracted sleeve over the extended sleeve.
4. Close the gap between coupling nuts with the nut on the extended-sleeve connector.

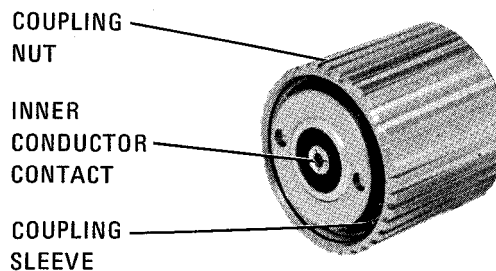
### To Disconnect

1. Loosen the coupling nut of the connector showing the wider gold band.



2. **IMPORTANT:** Part the connectors carefully to prevent striking the inner conductor contact.

- Care**
1. Keep contacting surfaces smooth and clean. Irregularities and foreign particles can degrade electrical performance.



2. Protect the contacting surfaces when the connector is not in use by leaving the coupling sleeve extended.
3. Use lintless material and/or firm-bristled brush such as a tooth brush for cleaning. If a cleaning fluid is needed, use isopropyl alcohol.

---

**NOTE**

---

Do not use aromatic or chlorinated hydrocarbons, esters, ethers, terpenes, higher alcohols, ketones, or ether-alcohols such as benzene, toluene, turpentine, dioxane, gasoline, cellosolve acetate, or carbon tetrachloride. Keep exposure of the connector parts to both the cleaning fluid and its vapors as brief as possible.

### Replacing the 7-mm Center Contact

Through wear or damage the contact in the center conductor may need replacing. This contact is a small four-pronged collet which snaps into a recess in the center conductor. This contact is normally held in by the spring-action of the four prongs. With a magnifying glass, examine this contact to determine if it needs replacement.

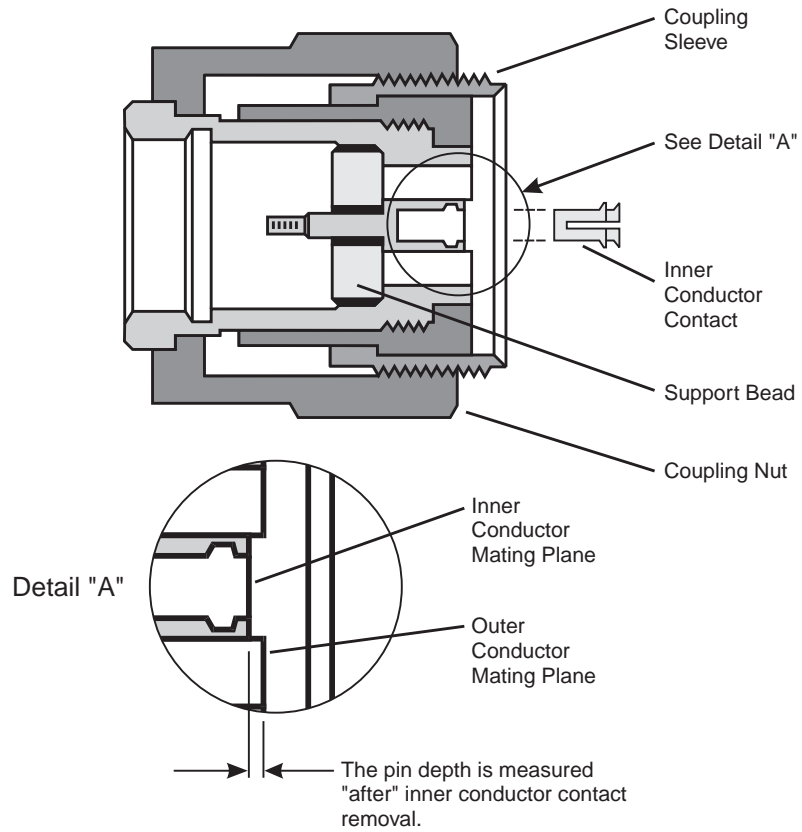
---

**CAUTION**

---

*DO NOT REMOVE THIS CONTACT FOR INSPECTION AS IT MAY BE DAMAGED BY REMOVAL.*

## Service Instructions



The contact should be free of burrs or wear and the prongs should be equally spaced. If the contact is removed, do *NOT* re-use it (it may be damaged by removal).

If the contact needs replacement and a new contact is available, proceed as follows:

1. Place the instrument so the connector faces down, if possible.
2. Tap the connector lightly and the contact should now protrude slightly. Insert the centering pin of the collet remover (HP 5060-0236) with the jaws open.
3. Allow the jaws on the tool used to close and pull straight back from the connector without twisting. The contact should come out with the tool. If not, repeat the process. Do *NOT* re-use the contact.
4. Snap in a new contact by pushing a new contact in place. Test the action of the new contact by pushing in on it. It should spring out again when released.